

Nov. 30, 1943.

R. HELL

2,335,410

METHOD OF TRANSMITTING CHARACTERS BY MEANS OF REVOLVING DRUMS

Filed Nov. 23, 1940

*Fig. 1.*

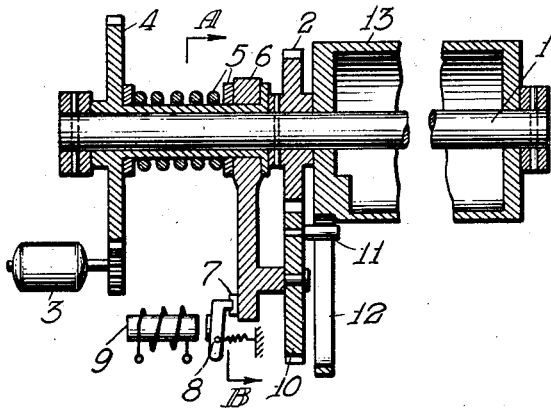

*Fig. 2.*

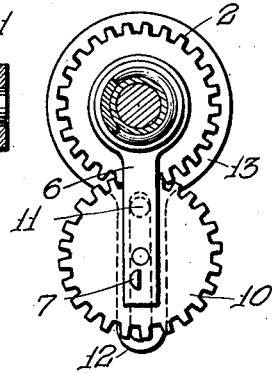

*Fig. 3.*

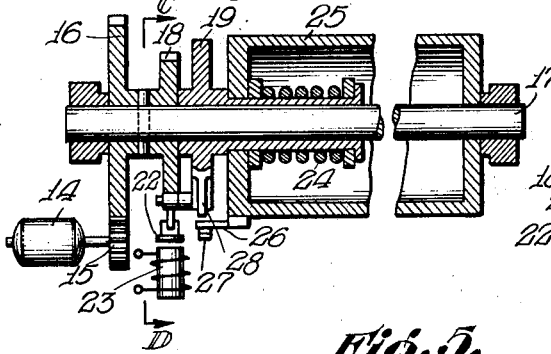

*Fig. 4.*



*Fig. 5.*



*Fig. 6.*



*Inventor:*  
*Rudolf Hell,*  
*by ~~Arthur~~ ~~Smith~~*  
*Attorney.*

# UNITED STATES PATENT OFFICE

2,335,410

## METHOD OF TRANSMITTING CHARACTERS BY MEANS OF REVOLVING DRUMS

Rudolf Hell, Berlin-Dahlem, Germany; vested in  
the Alien Property Custodian

Application November 23, 1940, Serial No. 366,932  
In Germany January 18, 1938

7 Claims. (Cl. 178—5)

This invention relates to a method of transmitting characters by means of revolving drums.

Arrangements for the transmission of characters are well known in the art in which a transmitting drum with characters built up of image points is employed. The individual scanning lines of the characters are produced in this case one after the other on the peripheral line of the drum. At the receiving end the characters transmitted as sequences of image points are again correspondingly composed. The scanning springs are, as is well known, brought into engagement with the drum in its position of rest at the transmission side by actuating keys and are removed from the same after the drum has made a complete rotation. In this case it is preferable to automatically stop the transmitting drum upon the completion of each rotation and to start the same again by depressing another key. Such methods do not permit an efficient operation of the key board unless at least five characters per second can be transmitted. It is therefore necessary to accelerate in a very rapid manner the relatively great mass of the transmitting drum and to stop the same immediately. Such apparatus produce in practice an objectionable noise and a considerable wear of the coupling arrangement.

The present invention has for its object to provide an improved arrangement, whereby the transmission of five and even more characters per second is made possible without it being necessary to suddenly accelerate or brake the transmitting drum or the corresponding member at the receiving side.

According to the invention the drum is not suddenly started, but gradually accelerated and retarded before stopping, and the necessary measures are taken to compensate for the influence of the non-uniform drum speed on the transmission of the image elements.

It is known in the art when employing apparatus for the transmission of images to couple the image drum gradually with the driving device so that it starts smoothly and attains the full speed after a given period. A retardation of the drum for stopping the same according to the invention is not provided in this arrangement, since the image drum is not stopped after each rotation. The braking and the retardation prior to the stopping in the case of masses, for instance, of the type drum of a typewriter moved instantaneously in rapid sequence is well known in the art. In these arrangements a gradual starting is also not possible. Since in these latter

two arrangements other transmission methods differing from that of the invention are employed, no measures have been taken to compensate for the influence of the non-uniform drum speed on the transmission of the characters.

The measures according to the invention for compensating the non-uniform drum speed may consist in the fact that the scanning member at the receiving end is driven with the same non-uniform speed as the transmitting drum. However, also the scanning lines and the character elements may be arranged on the drum in a distorted manner. The predistortion of the image to be transmitted is effected as is well known by cathode-ray receivers for compensating the distortions resulting during the magnetic deflection. Here the predistortion is effected by the optical method.

The non-uniform drive of the transmitting and receiving system may be effected according to the invention by means of a gearing which converts the uniform rotation of the driving motor into a rotation with non-uniform speed. Such gearings are well known as double cranks, crank knees, anti-parallel cranks and three-wheel gearings or the like. The drive may naturally be also effected with the aid of a crank or other arrangements. In these gearings the roller is started and stopped according to a predetermined function.

Fig. 1 shows a longitudinal sectional view and Fig. 2 a cross-sectional view taken on the line A—B of Fig. 1 of the arrangement according to the invention. In this embodiment one retarded starting of the drum is attained by the employment of a cycloid gearing. In this case a fixed gear 2 is mounted on the stationary shaft 1. The driving motor 3 rotates the revolving gear 4 and the latter, with the aid of the friction coupling elements 5, rotates the arm 6, except when the lug 7 is in engagement with the armature 8 of the magnet 9. The gear 10 meshing with the stationary gear 2 is rotatably mounted on the coupling arm 6. The driving gear pin 11 moves in the slotted arm 12 which is secured to the drum 13. The drum 13 is rotatably mounted on the shaft 1. In Fig. 1 the parts are shown in the position of rest. If the magnet 9 is energized and the magnet armature 8 is attracted, the lug 7 is released. The arm 6 thereupon begins immediately to rotate with the speed of the gear 4. By means of the stationary gear 2 and the revolving gear 10 the driving gear pin 11 as well as the drum 13 are started at a slowly accelerated angular speed and the maximum speed thereof

is reached after a revolution of 180°, the rotation being then slowly retarded as at the beginning and still more later on. Shortly before reaching again the initial position, the speed of the drum 13 is extremely small. If the magnet 9 is not energized the armature 8 will stop the nose 7 and the drum 13 will practically come to rest without impact.

In this embodiment it is assumed that the diameters of the gears 2 and 10 are equal. The starting curve of the drum may be varied by varying the gear diameter as well as by varying the position of the driving gear pin 11 on the gear 10.

The constructions so far mentioned employ a gearing between the driving shaft and the roller, which gearing starts the drum accurately according to a predetermined function. It is also possible to start and stop the drum not according to a predetermined function, but to cause the drum to start slowly and brake slowly by means of a sliding clutch (friction clutch).

An embodiment for this purpose is shown in Figs. 3 and 4. The driving motor 14 rotates the shaft 17 firmly secured to the gear 16 through the gears 15, 16. On the shaft 17 is firmly secured a ratchet wheel 18 and loosely mounted thereon is a clutch part 19. The latter is provided as shown in Fig. 4 with a pawl 20 which is pressed against the ratchet wheel 18 with the aid of a spring 21, provided that the pawl 20 is not withdrawn by engagement with the armature 22 of the magnet 23. This known locking clutch in the released state of the magnet armature 22 connects the revolving shaft 17 with the clutch part 19. On the clutch part 19 is loosely mounted the drum 25 frictionally coupled by the spring 24. The drum 25 is also loosely mounted on the revolving shaft 17. The drum 25 carries a driving drum pin 26 which when the drum is at rest is in engagement with the plate spring 27. A nose 28 arranged on the clutch part 19 can rotate the pin 26. If the magnet 23 is energized by a starting impulse and the armature 22 is attracted, the pawl 20 comes into engagement with the continuously revolving ratchet wheel 18 by the action of the spring 21, thereby causing the part 19 to rotate with the speed of the shaft 17. The revolving clutch part 19 will set the drum 25 relatively slowly and above all smoothly in rotation under the action of the very loosely adjusted spring 24 so that the pin 26 comes out of engagement with the spring 27. The spring 24 is so adjusted that in the case of the splitting up of the characters into seven lines as is assumed in this case the nose 28 has caught up with the pin 26 at the latest after a rotation of 60° and rotates the drum 25 at full speed owing to the rigid coupling brought about between the pin 26 and nose 28 of the clutch part 19. As soon as the part 19 has made one complete rotation the latter upon the release of the magnet armature 22 is disengaged from the ratchet wheel 18 by the pawl 20 and the clutch part 19 comes to rest. The drum 25 continues to rotate by means of its inertia at a gradually reduced speed until the pin 26 comes into engagement with the spring 27 and the drum 25 stops.

Starting and stopping of the drum is effected in this case in a completely smooth manner. A rigid coupling between the clutch part 19 and the drum 25 is brought about in the embodiment shown only for a rotation of 300° of the clutch part 19, whereas for the duration of the remaining rotation no rigid coupling is brought about.

The starting and the braking of the drum is not effected according to a predetermined function. It is therefore necessary to distribute the image points over 300° of the periphery of the drum, whereas the remaining 60° must be free of image points. This fact may be utilized to transmit the intervals between the individual characters. The clutch part 19 is stopped in this arrangement sooner than the drum 25. With the aid of a particular arrangement it is possible to transmit further signals as soon as the drum has come to rest.

In Fig. 6 is shown the distribution of the individual image points on the periphery of the drum for the character H. The first line from 28—29 which is scanned upon the starting of the drum is shortened to half the length of the lines; the following five lines 29—30 which carry the character elements have the normal length, whereas the last line 30—31 is again shortened.

The drive of the drum by means of a gearing as in the embodiment shown in Figs. 1 and 2 is accelerated and retarded according to a predetermined function. If in this case the individual image points on the transmitting drum have the same lengths, the image points are transmitted with different duration of transmission. When recording such a transmission with a standard receiver a distorted image is produced.

According to the invention the scanning member of the receiver is driven at the same non-uniform speed as the transmitting drum. By this measure a normal record of the characters is again produced. However, image points which are recorded with the same length are transmitted whose durations of transmission differ from one another.

With speeds of transmission which utilize the total band width necessary for the transmission, the transmission of characters of the same length whose periods of transmission differ from one another is unfavorable. Consequently, the differences in the duration of transmission resulting from the non-uniform speed of the drum are compensated according to the invention by the fact that the single lines and image points are arranged on the drum in a distorted manner. The distortion is effected to such a great extent in accordance with the known start and stop speed of the drum that the image points of equal length are again transmitted within equal durations of transmission.

In Fig. 5 is shown for the embodiment according to Figs. 1 and 2 the necessary distortion of the lengths of the image points for the character H. Here the central line is longest, whereas the outer lines are more and more shorter. In such arrangements it is, of course, possible to employ as receivers, receivers of any suitable type. If a receiver is arranged with a continuously driven receiving member which is practically instantaneously started and stopped in a known manner there easily results an undistorted recording of the characters. If the receiving member is started at a given acceleration and retarded over an appreciable interval it is necessary to compensate the scanning of the scanning device in order to attain an undistorted record.

What is claimed is:

1. In apparatus for transmitting characters, a rotatable record of characters to be transmitted, a uniformly rotating motor for driving said record, and gear means interposed between said motor and said record for converting the uniform speed of said motor to drive the said record at a

non-uniform speed from the beginning to the end of each revolution thereof, said gear means comprising a rotatable member loosely coupled with said motor, a gear wheel actuated by said rotatable member, and a coupling pin on said gear wheel engaging a slotted member on said record.

2. In apparatus for transmitting characters, a rotatable record of characters to be transmitted, a uniformly rotating motor for driving said record, and gear means interposed between said motor and said record for converting the uniform speed of said motor to drive the said record at a non-uniform speed from the beginning to the end of each revolution thereof, said gear means comprising a ratchet coupled with said motor, a follower carrying a pawl for engagement with said ratchet, means for engaging said pawl in said ratchet, and means on said follower for driving said record.

3. In a telegraph transmitter of the facsimile type, a rotatable record of characters to be transmitted, and means for rotating said record at a variable speed comprising a fixed gear on the rotational axis of said record, a planetary gear and means for rotating it around said fixed gear, and a driving connection between said planetary gear and said record.

4. A telegraph transmitter as claimed in claim 3, wherein the driving connection comprises a

pin on the planetary gear and a slotted member secured to the record.

5. In a telegraph transmitter of the facsimile type, a rotatable record of characters to be transmitted, means for rotating said record, start stop means for introducing a delay between successive rotations of the record, and means included in said rotating means for causing the record to accelerate gradually at the beginning of each rotation and to slow down gradually at the end of each rotation.

6. A start stop facsimile telegraph transmitter comprising a rotatable record of characters to be transmitted, a relatively constant speed motor for driving said record, and speed changing means interposed between said motor and record adapted to cause the record to rotate at a slower speed during periods at the beginning and end of each rotation than it rotates during the remainder of each rotation.

7. A start stop facsimile telegraph transmitter as claimed in claim 6, including a friction clutch to drive the record at the beginning of each rotation, a positive coupling to drive the record after substantial acceleration thereof by said friction clutch, and means for disconnecting the positive coupling before the record completes its rotation.

RUDOLF HELL.