

Nov. 3, 1953

R. HELL

2,658,106

FACSIMILE PRINTING TELEGRAPH SYSTEM

Filed June 27, 1950

3 Sheets-Sheet 1

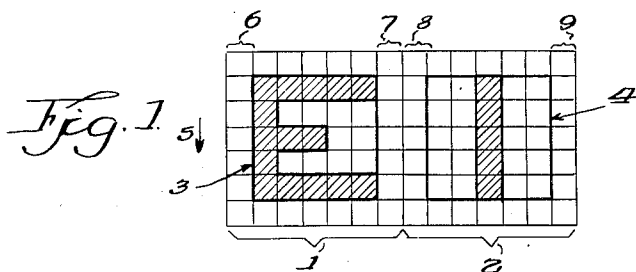
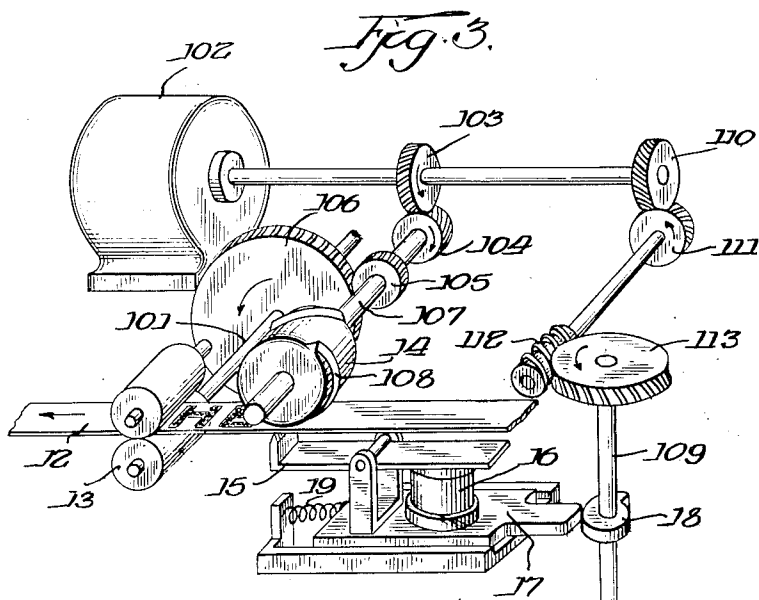

Fig. 2.



Inventor.
Rudolf Hell.

By *[Signature]*
Atty.

Nov. 3, 1953

R. HELL

2,658,106

FACSIMILE PRINTING TELEGRAPH SYSTEM

Filed June 27, 1950

3 Sheets-Sheet 2

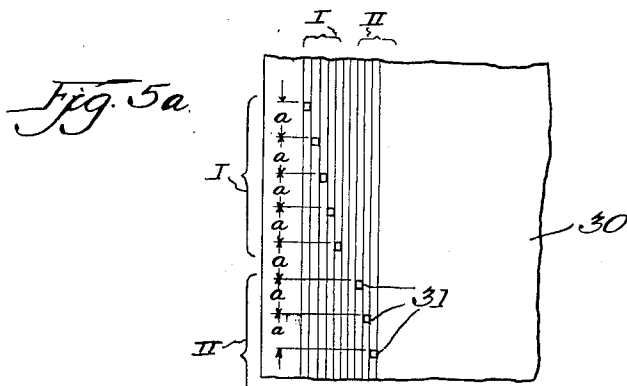
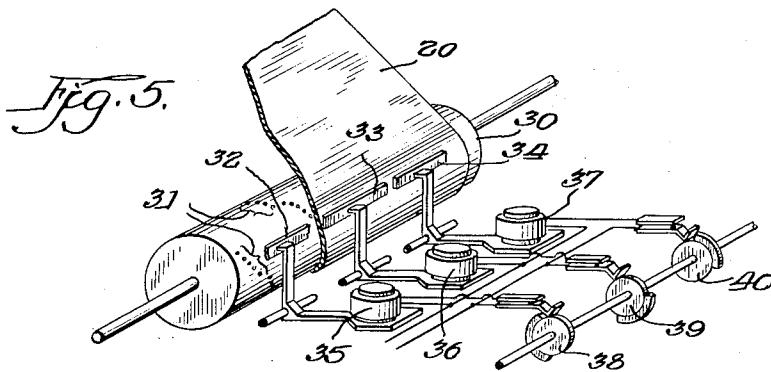
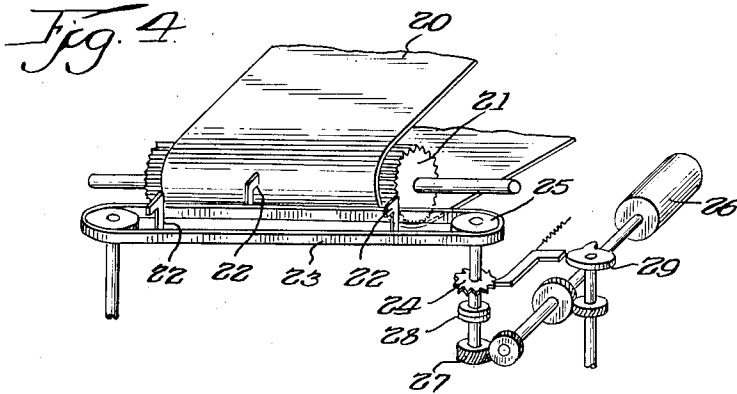

Inventor:
Rudolf Hell.
By *[Signature]* Atty.

Nov. 3, 1953

R. HELL

2,658,106

FACSIMILE PRINTING TELEGRAPH SYSTEM

Filed June 27, 1950

3 Sheets-Sheet 3

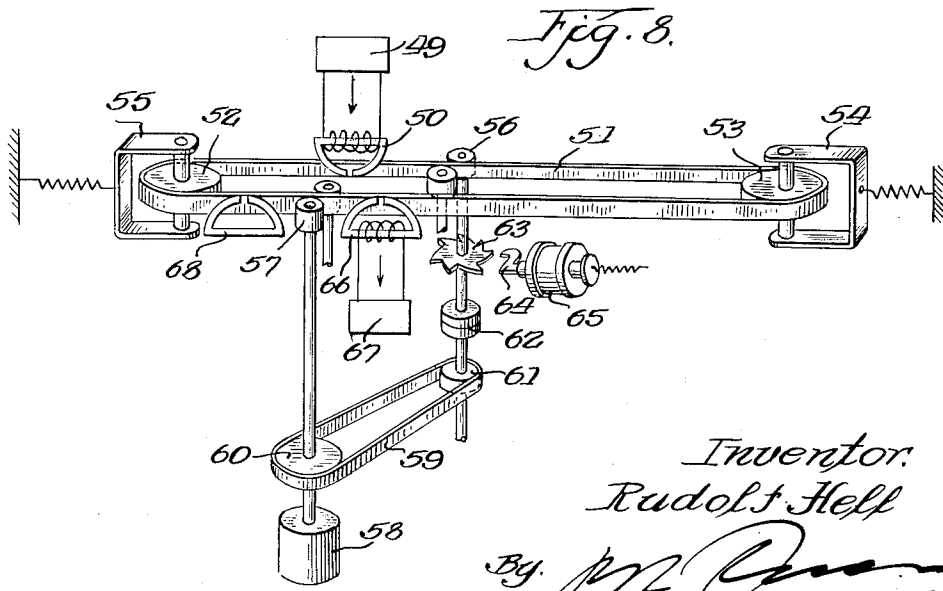
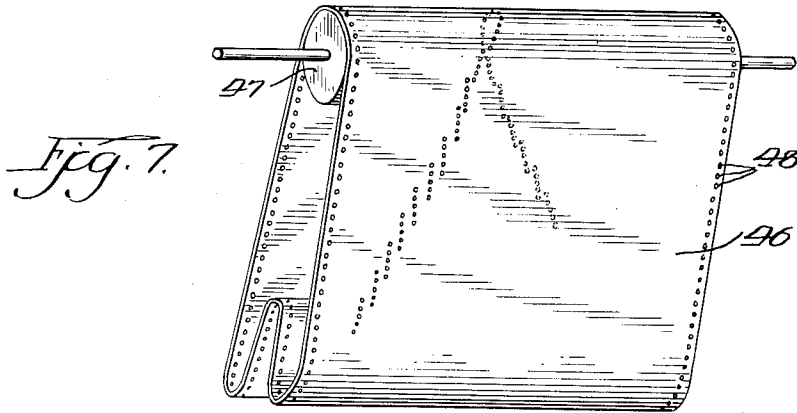
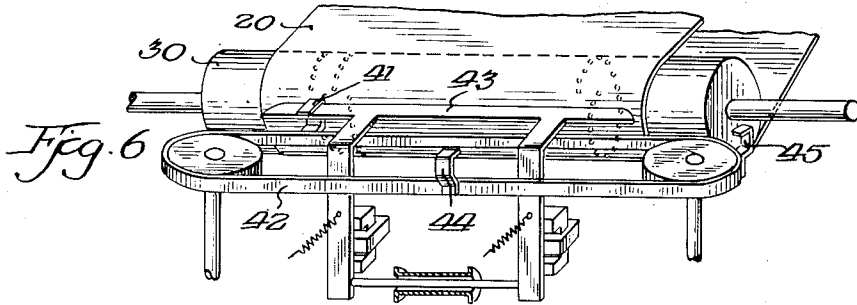

Inventor:
Rudolf Hell

By *[Signature]*
Att'y

UNITED STATES PATENT OFFICE

2,658,106

FACSIMILE PRINTING TELEGRAPH SYSTEM AND APPARATUS

Rudolf Hell, Kiel-Dietrichsdorf, Germany, assignor to Siemens & Halske, Aktiengesellschaft, Berlin-Siemensstadt and Munich, Germany, a German corporation

Application June 27, 1950, Serial No. 170,552

Claims priority, application Germany
July 1, 1949

23 Claims. (Cl. 178—30)

1

2

This invention relates to a printing telegraph system, and is particularly concerned with a system comprising means for automatically spacing the characters to be printed in the receiver.

The principal object of the invention is to increase the speed of operation in the transmission and the printing of the signals, e. g., in systems forming characters and character lines in the manner as generally described in U. S. Patents Nos. 2,046,328 (Kleinschmidt) and 2,298,276 (Burcky), in which the individual characters are subdivided into image points or dots which are transmitted in the form of series of signal impulses for the actuation of sensing and printing elements in the receiver in rhythm with the incoming signal impulses.

This principal object is realized by the provision of a printer comprising a continuously advancing record tape or sheet and having means for automatically interposing the spacing intervals required between symbols or characters to be printed thereon, thus eliminating the necessity for transmitting special spacing signals.

The invention may be realized in the case of printer structures conforming generally to those described in the above mentioned patents by superposing upon the continuous motion of certain printing elements abrupt reset motions always at the conclusion of the printing of a character so as to provide for continuous and uninterrupted printing of successive symbols or characters.

The intervals between symbols or characters may be utilized for the transmission of synchronizing impulses.

In certain embodiments of the invention there is provided a platen carrying printing points or buttons disposed in groups corresponding to characters or symbols to be printed, and the groups of buttons may be spaced so as to automatically interpose the spacing between symbols or characters.

In accordance with another object, the invention provides a translator device which receives signals corresponding to symbols or characters, and also signals corresponding to the spacing between characters, and which automatically cancels the spacing signals so as to provide a record comprising series of signal impulses corresponding to symbols or characters only, for the operation of the receiver.

The foregoing and additional objects and features will appear in the course of the detailed description which will presently be rendered with reference to the accompanying drawings. In these drawings,

Fig. 1 is a diagrammatic representation showing scanning fields for symbols or characters;

Fig. 2 illustrates diagrammatically the arrangement of successive signal impulses for the sending and recording of one particular symbol;

Fig. 3 shows in diagrammatic manner essential parts of a tape printer made in accordance with the invention;

Figs. 4-7 are diagrammatic views of essential parts of sheet printers made in accordance with the invention; and

Fig. 8 illustrates in diagrammatic manner a signal impulse translator.

Referring now to Fig. 1: numerals 1 and 2 indicate two symbol fields each containing a symbol in positions as they successively appear in a symbol line, the symbols being assumed to be the letters "E" and "I." All symbol fields are of identical size. The symbol areas 3, 4 in the various fields are likewise of identical size, as indicated by the full lines framing each symbol area. The symbol area 3 is nearly completely filled with the letter "E," while the letter "I" occupies only the central sensing or scanning line of the symbol area 4. The scanning of the symbols proceeds in downward direction, as seen in the drawing, namely, in the direction of the arrow 5. Each symbol field is in the example shown subdivided into seven scanning lines so that the entire field is subdivided into $7 \times 7 = 49$ symbol image dots.

In the transmission of symbols of this type, as practiced heretofore, e. g., in the system disclosed in the previously mentioned Kleinschmidt Patent 2,046,328 each of the seven scanning lines is scanned throughout its length, at the sender and at the receiver, and the individual dots in the corresponding field are transmitted as spacing and as signal impulses, respectively. The scanning lines 6 and 7 never contain symbol image dots, since such dots appear only within the symbol areas such as 3 and 4. The marginal lines 6, 7 and 8, 9 therefore were heretofore always transmitted as signals to denote spacing. The right margin 7 of the preceding symbol resulted with the left margin 8 of the next successive symbol in a symbol space. The spaces between symbols and also the horizontal margins disposed above and below the symbol areas were therefore always transmitted as spacing signals.

In accordance with its principal object, the invention omits from the scanning or sensing operations the gaps 6, 7, 8, 9 and, if desired, also the upper and lower margins of the symbols, thus limiting the scanning to the symbol or character areas such as 3 and 4. The time for scan-

ning the marginal areas is thus completely eliminated. It follows therefore that the transmission of the signal impulses for a symbol required in accordance with previous practice the scanning of 49 image dots, while the invention saves the time for scanning the 14 dots of the scanning lines at the sides of the symbol and, if desired, in addition the time for the 10 scanning dots in the upper and lower marginal lines. Instead of having to transmit signal impulses corresponding to 49 image dots, the system according to the invention thus scans and transmits only impulses corresponding to the 25 dots within the symbol area of a particular symbol.

Since the invention also contemplates the transmission of synchronizing impulses, e. g., two impulses between each two symbols, there are needed for the practice of the present transmission method 27 image dots as compared with 49 dots required in previous systems. This amounts to approximately forty-five per cent saving in transmission time, without altering the telegraphic speed of transmission of the corresponding signal impulses.

The sequence of transmission of the signal impulses, and including the synchronizing impulses, is apparent from Fig. 2. The cross-hatched portions in this figure denote the signal impulses required for the symbol "E" and the open portions indicate the synchronizing impulses. The synchronizing impulses follow the signal impulses without pause. The signal impulses for the next successive symbol follow immediately after the synchronizing impulses.

Fig. 3 shows the essential parts of a tape printer operating along the general principles as described in the Kleinschmidt Patent 2,046,323. The tape 12 is continuously moved in the direction of the arrow by means of the driving roller 13. The driving roller 13 is carried on the shaft 101 which is continuously rotated by the motor 102 through the medium of the gears 103, 104, 105, 106. The tape 12 moves underneath the continuously rotating printing spindle 14 which is fastened on the shaft 107 carrying the gear wheels 104, 105.

The printing spindle 14 carries one or more, for example, as shown, two spirally disposed printing edges 108, which extend over its width and which become alternately operable during the rotation of the spindle. The number of these printing edges 108 and the ratio of rotation of the shafts 101 and 107 will depend on the number of lines or points of which the characters or symbols to be printed are composed.

The reproduction, that is, the printing, of the symbols takes place by the actuation of the printing bar 15 carried by the armature of the printer magnet 16 which is successively energized by the signal impulses transmitted to the printer. Whenever the magnet 16 is energized, it actuates its armature and presses the edge of the printing bar 15 against a definite point along the printing edge 108 on the spindle 14. The position of this definite point depends on the angular position of the printing spindle. Since this spindle rotates continuously, the point of intersection between the spirally disposed printing edge 108 and the free edge of the printing bar 15 will move periodically transverse of the tape 12. The displacement of the printing bar 15 relative to the spirally formed printing edge 108 produces upon the tape 12 printing marks or impressions, by the use of a suitable inked ribbon or the like, not shown, which is disposed between the spindle 14 and the ribbon 12. These impressions form the

characters, two of which, namely, the characters H and E, are indicated in Fig. 3.

In the known printers, the spaces between two successive characters are formed by interposing a signal, e. g., a transmission pause, of corresponding duration, thus entailing a loss in transmission time. In accordance with the invention, this loss is eliminated by interposing between two successive characters a printing gap by abrupt operation or resetting of the printing bar 15 so that the printing of the successive symbol can proceed without any interruption.

The printing bar 15 and preferably also the printer magnet 16 are for this purpose disposed on a slide 17 which is mounted on guideways, as shown, and which is displaced by the control cam 18 against the pressure of the spring 19.

The cam 18 is carried on the shaft 109 and is continuously rotated by the motor 102 through the medium of the gear wheels 110, 111, worm 112 and worm wheel 113, the rotation being in the direction indicated by the arrow on the worm wheel 113, the speed of continuous rotation of the cam being such that it describes, during the scanning of a complete character, exactly one revolution. The cam curve extends along a steadily increasing radius so that the slide 17 and therewith the printing bar 15 of the armature are steadily moved in the direction of the advance of the tape 12. The entire advance of the slide 17 and the printing bar 15 in the direction of the character line thereby equals the desired width of the gap between two symbols.

Upon completion of the printing of a symbol, the control cam 18 will be in an angular position relative to the slide 17 which corresponds to its greatest radius. The rearward extension of the slide 17 then falls in back of the cam tooth; i. e., the slide and with it the printing bar 15 move abruptly to the right, as shown in the drawing, by a distance which corresponds to the width of the gap between two symbols, so that the next successive symbol is immediately printed in proper spacing from the preceding symbol.

The steady, continuous advance of the slide 17 is resumed by the operation of the control cam 18, and the above described interplay is in this manner repeated with the printing of each successive symbol.

The required spacing between the symbols is in this manner automatically produced. The impulse series denoting the successive symbols are interrupted for only the very short periods which may be needed for the transmission of synchronizing impulses.

Instead of abruptly moving the printing bar 15 at the conclusion of the printing of each symbol, it is of course possible to provide means analogous to those for the displacement of the slide 17 for imparting an abrupt advance motion to the tape 12 at the conclusion of the printing of each symbol by a predetermined amount which corresponds to the spacing between the symbols.

The embodiment shown in Fig. 4 shows an example of a printer which employs the fragmentary character printing shown, e. g., in Burcky Patent 2,298,276. There are provided a number of printing members 22 which are carried by an endless belt and are moved continuously relative to the record sheet 20. The printing takes place by the coaction of the printing members 22 with the longitudinal ribs of the platen 21 which rotates to advance the record sheet 20.

The scanning and printing member 22, which is at any time operative, is pressed inwardly against the sheet 20 and the platen 21, in rhythm

5

6

with the incoming signal impulses, by suitable electromagnetic means, not shown in the drawing. The platen 21 rotates while the corresponding scanning member 22 moves laterally, being advanced by the belt or strip 23, so that the individual image points are successively sensed and printed on the record sheet 20. The printing of the image dots may be accomplished by the use of a suitable carbon sheet or the like, not shown.

The invention as compared with the patented arrangement comprises means, as shown in Fig. 4, for superimposing upon the continuous motion of the printing members 22, in the direction of the character line, successive abrupt motions which are always interposed between two successive symbols, so as to automatically produce the spacing between symbols. This operation is accomplished by the cam 29 which causes rotation, by a definite angular amount, of the toothed wheel 24 relative to the slip-clutch 23, always upon completion of the printing of a symbol, thus altering the continuous advance of the printing members 22 always by an abrupt advance of a definite amount. Numeral 25 in Fig. 4 designates the drive motor; 27 is the coupling gear; and 28 is the driving roller for the endless belt carrying the printing members 22.

The printing of the next successive character can in this manner again start practically immediately upon the completion of the preceding character, without interposing any special interval, as heretofore required, and thereby avoiding loss of valuable transmission time.

As in the case of the first described structure, shown in Fig. 3, it is also possible in this case to impart to the platen 21, and therewith to the record sheet 20, an abrupt transverse motion at the completion of the printing of a symbol, by using for the displacement of the platen means analogous to those indicated for imparting the abrupt motion to the printing members 22.

Fig. 5 illustrates particularly simple means for realizing the invention. As shown, the record sheet 20 moves over a platen 30 which carries pointlike sensing or printing points or buttons 31. These buttons are arranged in groups of five which always form a section of a spiral, while the next succeeding five points are staggered relative to said spiral section by the width of a symbol space.

The distribution and arrangement of these scanning or printing points or buttons is apparent from Fig. 5a which shows a partial developed view of the platen 30. It is assumed that the symbol field, which is filled by a symbol, is subdivided into five parallel sensing portions, as shown in Fig. 1. There are in such a case five printing or sensing buttons 31 which are disposed successively longitudinally of the platen 30. These buttons are staggered by the spaces a which correspond to the height of the symbol. The invention is in this embodiment realized by spacing the last printing button belonging to one symbol field, e. g., to the field I in Fig. 5a, from the first button belonging to the next successive symbol field, i. e., the symbol field II in Fig. 5a, longitudinally of the platen 30, that is, in the direction of the symbol line, by a distance which corresponds to the desired spacing between symbols. The spacing a between the buttons of each group I, II, etc., remains the same, being equal to the height of a symbol. The spacing of the last button of one group from the first button of the next successive group may be slightly increased, if it is desired to transmit a

synchronizing signal between series of signals denoting the symbols.

The scanning and printing is accomplished by the use of printer bars 32, 33, 34 which are pressed against the record sheet 20 and therewith against the scanning points or buttons on the platen 30 in rhythm with the incoming telegraphic signals under the control of the electromagnets 35, 36 and 37, respectively. The scanning buttons are arranged on the platen 30 in the form of three spiral paths in order to avoid undesired increase of the diameter of the platen 30. Three printer bars 32, 33, 34 are provided, one for each one-third of the symbol line. The printer magnets 35, 36, 37 are successively switched in so that only one printer mechanism is at any time effective. Three cam disks 38, 39 and 40, respectively, are provided, one for operatively controlling the actuation of each of the printer bars 32, 33 and 34. The arrangement thus accomplishes scanning and printing of the symbols by successively affecting the first, second and finally the third spiral paths formed by the scanning buttons. After the third printer bar 34 has scanned the third spiral path to the end of the symbol line, the first bar 32 again becomes operative for printing the next line. The successive operative actuation of the three bars is controlled by the cam disks 38, 39, 40 each carrying a cam which extends over one-third of its circumference, each cam being angularly staggered by one-third of its path of rotation with respect to the other cams. The cams govern the closing and opening of associated contacts which control the circuits of the respective electromagnets for actuating the corresponding printer bars 32, 33, 34.

The individual sections or portions of the spirally arranged scanning points 31 are staggered relative to each other, so that after five successive points have been scanned for the five scanning lines of a symbol, the first point of the next section of five succeeding scanning points appears in front of the corresponding printer bar 32, 33, 34 to be sensed thereby within the next successive symbol area which is removed by the width of a symbol space from the preceding symbol area. The height or width of each printer bar 32, 33, 34 corresponds to the height of a symbol, that is, to the length of a vertical scanning line extending through the symbol from top to bottom. The length of each printer bar corresponds to the width covered on the platen by one spiral path.

The number of spiral paths used determines the number of printer bars to be provided. A particularly suitable subdivision results from the use of 25 scanning buttons forming a spiral for the scanning of five symbols. If it is assumed that a symbol line contains 70 symbols, we will then have a total of 14 spiral paths with 14 printer bars, respectively, associated therewith and each printer bar individually operable as described.

The diameter of the platen may be kept relatively small by the provision of a relatively large number of spiral paths.

A common continuously operable printer bar, as shown in Fig. 6, may be provided in order to avoid the necessity of employing several individual bars corresponding to a like number of spiral paths. A sensing and printer element 41 is employed in this case which corresponds in height to the height of a character or symbol and in width axially of the platen 30 to the width covered by one spiral path. This element

is steadily moved in lateral direction by an endless belt 42 in similar manner as the scanning and printing elements 22 are moved in the structure shown in Fig. 4, and is pressed against the record sheet 20 and the platen 30 by the inward displacement of the common printer bar 43 under control of an electromagnet responsive to signal impulses delivered thereto. The bar 43 extends substantially over the length of the platen 30, as shown. Two printer elements 44, 45 are provided in addition to the one shown at 41, in order to obtain continuous printing of the successive symbol lines on the record sheet.

A single printer bar extending alongside the platen without coating printer elements as shown in Fig. 6 would be sufficient, provided the platen would carry only one single spiral path. Such an arrangement would result in an unwieldy structure because of the necessarily large platen diameter.

The structure shown in Fig. 7 therefore proposes to dispose the scanning buttons in a single, large spiral path upon the endless sheet 46 instead of directly on the platen 47, the platen functioning as a drive for the sheet 46. Perforations 48 on each side of the strip 46 take care of proper advance thereof, in coaction with corresponding sprocket teeth carried by the platen.

The translator arrangement shown schematically in Fig. 8 is preferably employed in conjunction with the translator-transmitter 49, which may be operated under control of a transmission record carrying impressions, i. e., indicia or punchings corresponding to image dots to be transmitted as signal impulses as well as indicia denoting spacing signals. The impulses produced by the translator-transmitter 49, composed of groups of signal impulses and spacing signals, are conducted to the winding of the recording head 50 which coats with the magnetic carrier 51. The latter may of course be in the form of an endless tape, wire or the like which extends over the rollers 52, 53. These rollers are carried by the yokes 54, 55 which are elastically mounted, as indicated, for the purpose of compensating for variations resulting from nonuniform advance of the tape 51. Two drive rollers 56, 57 are provided, one for each flight of the tape 51. The roller 57 is driven directly by the motor 58; while the roller 56 is driven faster through the medium of a belt 59 and the rollers 60, 61 which are of different diameter, as shown. The shaft for the roller 56 carries a friction clutch 62 and a detent ratchet 63. A detent pawl 64 is provided for coaction with the detent ratchet 63 under control of the electromagnet 65. The latter is operatively effective for stopping the drive rollers 56 during the intervals of spacing signals transmitted by the device 49, while permitting free operation of the roller 56 during transmission of the symbol signal impulses. The result is that the individual symbol signal impulses are recorded on the tape 51 without the spacing signals. The drive roller 57 rotates continuously so that the signals are continuously transmitted to the amplifier 67 by the receiving head 66. The successive groups of signal impulses are then transmitted from the amplifier 67 for scanning and printing, as already described. The arrangement therefore accomplishes translation of the signal record containing pauses into continuous impulse series which are free of pauses. The impulses recorded on the tape 51 are cancelled by the head 68, after having been picked up for transmission, and new series of signal

impulses are continuously impressed on the tape for subsequent transmission.

The above noted arrangement may of course be modified for reverse operation, in such a manner, that the successive groups of impulses are recorded on the tape 51 with the pauses denoting spacing signals, and are taken from the tape without such pauses. The recording tape in such an arrangement would have to pass the recording head 50 in a continuous, steady motion, while passing the receiving head 66 in a steplike intermittent motion.

Changes may be made within the scope and spirit of the accompanying claims.

I claim:

1. Apparatus for printing successive groups of signal impulses each group denoting solely a symbol exclusive of signals denoting the spacing between symbols, comprising a record member, means for continuously advancing said record member, means for successively receiving said groups of signal impulses, means for printing on said continuously advancing record member impressions corresponding to said signal impulses to form thereon the symbols corresponding thereto, and means for controlling said printing means to produce automatically the spacing between adjacent symbols.

2. The apparatus defined in claim 1, together with means forming a transmission record carrying impressions corresponding to said groups of signal impulses for transmitting such impulses to said printing apparatus.

3. The apparatus defined in claim 1, together with means forming an initial transmission record carrying impressions including impressions corresponding to said groups of signal impulses and impressions denoting spacing signals corresponding to spacings between symbols represented by successive groups of said signal impulses, and means for translating said initial record to form an intermediate transmission record excluding said spacing signals.

4. Teleprinter receiver apparatus for recording on a record member messages composed of symbols designated by signals comprising means for continuously advancing said record member, means for successively receiving successive groups of signal impulses each group denoting solely a symbol exclusive of spacing signals representing spacings between symbols, sensing means for sensing the signal impulses in each group of impulses and for printing impressions of such impulses on said record member to form the symbols thereon corresponding to said signal impulses, and switching means effective at the conclusion of the printing of said impulse impressions for each symbol for abruptly switching the relative position between said sensing means and said record member to dispose said sensing means in starting position for the next successive symbol in spaced relation to the preceding symbol.

5. The apparatus defined in claim 4, wherein a tape constitutes said record member, and means for advancing said tape by successive steady and abrupt increments of motion.

6. The apparatus defined in claim 4, wherein a tape constitutes said record member, and means for advancing said sensing means during the sensing thereof of any group of said impulses relative to said tape by a distance corresponding to the width of a space between symbols and for restoring such sensing means to initial position

relative to said tape at the conclusion of the sensing thereby of any group of said impulses.

7. The apparatus defined in claim 4, wherein said sensing means is formed in the nature of a resilient member which is displaced during its sensing operation and abruptly returned to initial position under control of said switching means.

8. The apparatus defined in claim 4, wherein a sheet constitutes said record member which coacts with a suitable platen, and means for axially shifting said platen and said record sheet during the operation of said sensing means incident to the sensing of each group of signal impulses by an amount corresponding to the width of a space between symbols and for abruptly returning said platen and said record sheet to initial position at the conclusion of such sensing operation.

9. The apparatus defined in claim 4, wherein a sheet constitutes said record member which coacts with a suitable platen, together with means for shifting said platen and said record sheet at the conclusion of the sensing operation for each symbol by an amount corresponding to the spacing between symbols and for returning said platen and said record sheet to initial position at the conclusion of the sensing operations for a line of symbols.

10. The apparatus defined in claim 4, wherein a sheet constitutes said record member which coacts with a platen, together with means for imparting to said sensing means a dual motion axially of said platen and said record sheet, said dual motion including displacement of said sensing means in an axial steady motion and periodic abrupt displacement thereof in return direction which is superimposed on said steady motion.

11. The apparatus defined in claim 4, together with means for imparting to said sensing means a steady motion relative to said record member, and coupling means for displacing said sensing member abruptly by a predetermined increment at predetermined intervals.

12. The apparatus defined in claim 4, including a rotatable platen, said platen carrying sensing buttons spirally disposed thereon for scanning coaction with said sensing means to print said signal impulse impressions on a suitable record, the arrangement being such that each sensing button is effective to effect under control of said sensing means the printing on said record of impulse impressions along one scanning line of the corresponding symbol.

13. The apparatus defined in claim 4, including a rotatable platen, said platen carrying sets of sensing buttons forming staggered sections of a spiral thereon for scanning coaction with said sensing member to print said signal impulse impressions on a suitable record disposed between said platen and said sensing means, the staggering between said sections of said sensing buttons being such as to effect under control of said sensing means spacing between adjacent symbols printed on said record.

14. The apparatus defined in claim 4, including a rotatable platen carrying sets of sensing buttons spirally arranged thereon, said sensing means extending alongside said platen for the entire distance covered by said spirally disposed sensing buttons for scanning coaction therewith.

15. The apparatus defined in claim 4, including a rotatable platen carrying a plurality of sets of sensing buttons each set disposed spirally thereon, said sensing means comprising a plurality of sensing elements, and means for moving said elements axially of said platen for succes-

sive scanning coaction with said spirally disposed sets of sensing buttons.

16. In a facsimile telegraph printer having a record tape and means for advancing it and having a printer bar and electromagnetic means for actuating said printer bar responsive to successive signal impulses delivered thereto to cause said printer bar to print indicia on said tape forming successive symbols, a member for carrying said printer bar and said electromagnetic means, means for movably mounting said member, and means for displacing said member at the conclusion of the forming of each symbol to displace said printer bar and said electromagnetic means relative to said record tape to cause spacing between adjacent symbols.

17. In a facsimile telegraph printer having a rotatable platen and having a record receiving page disposed about said platen and movable therewith and having printing elements and means for moving said elements successively alongside said record-receiving page and having electromagnetic means for actuating said elements to print on said record-receiving page indicia forming symbols thereon, and means for abruptly altering the motion of said elements at the conclusion of the printing of each symbol to effect spacing between said symbols.

18. A facsimile telegraph printer comprising a rotatable platen and means for rotating it, a plurality of sets of scanning buttons disposed on said platen in successively staggered sections forming an irregular spiral thereon, a plurality of printer bars each for coaction with a predetermined set of scanning buttons, a record-receiving page disposed about said platen and movable therewith, electromagnetic means for actuating each printer bar responsive to signal impulses delivered thereto, and rotatable cam means for causing actuation of said electromagnetic means to operate the associated printer bars for the purpose of pressing said record-receiving page against the corresponding scanning buttons to print indicia on said page forming symbols thereon.

19. A facsimile telegraph printer comprising a rotatable platen and means for rotating it, scanning buttons spirally disposed on said platen, a record-receiving page disposed about said platen and movable therewith, a plurality of printer elements, means for moving said printer elements successively alongside said platen, a printer bar extending alongside said platen, and electromagnetic means for actuating said printer bar responsive to signal impulses delivered thereto for actuating the printer element moving alongside said platen against said record-receiving page to press said page against successive sections of said spirally disposed scanning buttons for the purpose of printing indicia on said page to form symbols thereon.

20. A facsimile telegraph printer comprising a rotatable platen and means for rotating it, an endless sheet moved by said platen and carrying means forming scanning points thereon, a record-receiving page disposed in front of said endless sheet and movable therewith and with said platen, a printer bar disposed alongside said record-receiving page, and electromagnetic means for actuating said printer bar responsive to signal impulses delivered thereto for pressing said record-receiving page against successive scanning points on said endless sheet to print indicia on said record-receiving page forming symbols thereon.

11

21. In a facsimile telegraph system, a signal impulse translating device comprising an endless magnetic carrier member and roller means for supporting it, driving means for each flight of said carrier member, means for periodically impeding the advance of one of the flights of said carrier member, transmitter means for impressing signal impulses upon one flight of said carrier member, and receiver means for picking up signal impulses from the other flight of said carrier member.

22. The device defined in claim 21, together

12

with means for elastically supporting the roller means for said carrier member.

23. The device defined in claim 21, wherein each driving means operates at different speed.

RUDOLF HELL.

References Cited in the file of this patent

UNITED STATES PATENTS

Number	Name	Date
2,046,328	Kleinschmidt	July 7, 1936
2,298,276	Burcky et al.	Oct. 13, 1942
2,457,133	Deloraine	Dec. 28, 1948